

What is the energy of an electric field?

Katsuo Sakai

Electrostatic generator Laboratory

phone: (81) 45-973-4014

e-mail: gy7a-ski@asahi-net.or.jp

Abstract— Today, most people think that an electric field has static energy. Therefore they think that after all energy of some place is changed to kinetic energy, the place cannot give another electric energy.

On the contrary, a few people think that electron radiates photons continuously and those photons make electric field. This means the energy of an electric field is not static, it is moving with light speed.

A simple experiment was performed to confirm which one is correct. In this experiment, a charged box conductor was moved to right by an electrostatic force in an electric field, then it was returned on the same path by tension of a thread. The measured return point shows the conductor was given the same energy from the electric field on the return path.

I. INTRODUCTION

Text book of electrostatics usually explains that electric field holds energy in a space. and It explains that we can not get energy from the same space again.

For example, in the book of "Fundamentals of Physics" [1], there is next sample problem (Sample Problem 25-6 P.671).

"A parallel-plate capacitor whose capacitance C is 13.5 pF is charged by a battery to a potential difference $V = 12.5$ V between its plates. The charging battery is now disconnected, and a porcelain slab ($k = 6,50$) is slipped between the plates.

(a) What is the potential energy of the capacitor before the slab is inserted?

Answer is 1055 pJ.

(b) What is the potential energy of the capacitor-slab device after the slab is inserted?

Answer is 162 pJ

After this answer, there is the following explanation.

"When the slab is introduced, the potential energy decreases by a factor of k .

The "missing" energy, in principle, would be apparent to the person who introduced the slab. The capacitor exert a tiny tug on the slab and would work on it in amount

$$W=(1055-162)\text{pJ}=893\text{pJ}$$

If the slab were allowed to slide between the plates with no restraint and if there were no friction, the slab would oscillate back and forth between the plates with a (constant) mechanical energy of 893pJ, and this system energy would transfer back and forth between kinetic energy of the moving slab and potential energy stored in the electric field.

I think this explanation is not easy for clear understanding. Therefore, I will add expanded explanation.

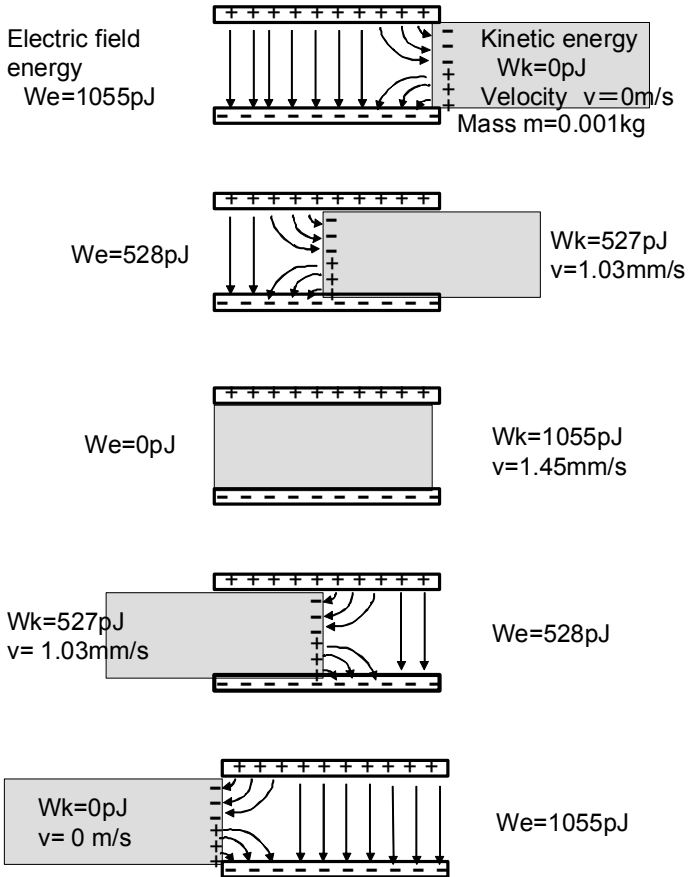

Fig. 1. Explanation of electrostatic force that pulls a conductor box into parallel electrode plates

In figure 1, upper and lower parallel plates are electrodes. A capacitor is consist of those electrodes. Positive and negative charges are distributed on those electrode as shown in figure 1.

Gray box shows a conductor box. The slab has been replaced by this conductor box. Because conductor is more understandable material than a dielectric material. Of course, there is thin insulating film on the electrodes.

The weight of this conductor is 1.0 gram. Arrow lines show line of electric force. In the left half of this capacitor, the arrow lines are straightly drawn from upper electrode to lower electrode. Because there is no effect of the conductor box.

However in the right half of this capacitor, the arrow lines are bend to the side wall of the conductor bpx as shown in figure 1. Because counter charge is induced here. As a result,

electrostatic force acts on the side wall perpendicularly and pulls this conductor box toward left.

Therefore, the conductor box moves to left slowly. When it arrived at the center of the capacitor, half of the potential energy stocked by the capacitor has been transferred to a kinetic energy of the conductor box. It is 527 pJ and the velocity of the conductor box is 1.03mm/sec.

Furthermore, the conductor box moves to left continuously. When it arrived at the end of the capacitor, the all potential energy stocked by the capacitor has been transferred to a kinetic energy of the conductor box and becomes zero. The velocity of the conductor box becomes 1.45mm/sec.

On this time there is not electrostatic force that can pull the conductor box toward left. However the box moves toward left furthermore by inertia force.

In this movement, the velocity becomes gradually slow. When the box passed through the center of the capacitor, the velocity decreases to 1.0m/sec. Lost kinetic energy of the box in this while is 527pJ. This energy has been changed to the potential energy of the right half of the capacitor.

The box moves toward left furthermore, and when finally it pass over the electrode plates, the velocity becomes zero. The lost kinetic energy of the box in this while is 528pJ. This energy has been changed to the potential energy of the left half of the capacitor.

The velocity becomes zero at this place. However an electrostatic force that can pull the conductor box toward right has happened as shown in figure 1. As a result, the box starts to move toward right.

After traversing of the capacitor, the velocity of the box becomes zero again. This situation is the same of the situation of the top (first) stage of the figure 1. Therefore, the box starts to move toward left again. This movement will be repeated endlessly.

This is my supplementary explanation. On this point of view, if the energy of an electric field is lost, namely it has been changed to kinetic energy. This space can not give new electric energy to the other box. Is it true or not?

A simple experiment was planned and executed for solving this question.

II. EXPERIMENT

A. Experimental instrument

Figure 2 shows the front view of the experimental instrument

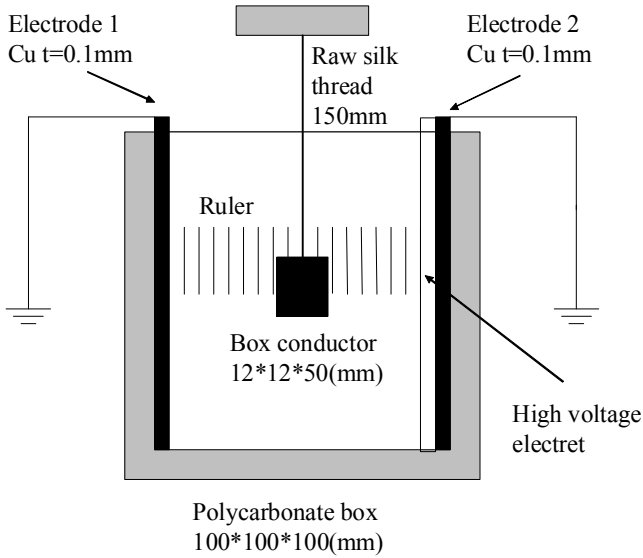

Fig. 2. The front view of the experimental instrument

This instrument consists of two parallel electrodes, an electret and a box conductor. They are arranged in a large box. A large transparent polycarbonate box was prepared. This box protects the small box conductor from wind that was blown from outside. This experiment was performed in open air condition, because it needs low humidity condition. But I had not a low humidity room. Therefore, it was performed on a good weather day in this winter. Low-humidity day were selected, and the experiments were performed with the window open to avoid the usual constant air condition of 25°C and 60%RH. On that day, the average temperature was 10°C and the average humidity was 30%RH.

The thin copper plate 100mm*100mm with a thickness of 0.1mm was attached to the left and right wall of the large box as a left and right electrode. The distance between both electrodes was 100 mm. The both electrodes were grounded. A small box conductor was floated by an insulating raw silk thread with a length of 150mm at the center of both electrodes. The width, the height and the length of the conductor was about 12 mm, 12mm and 50mm respectively. The material of the conductor was aluminum, and the thickness was 0.1mm.

The edges of the electrodes and the box were lightly rubbed by a fine sand-paper to prevent corona discharge. An electret (TOHFLON ELT SHEET made by TOHO KASEI Co., Ltd.) was attached on the right electrode. This special electret was used as high voltage power supply. The potential of this electret was 14kV. Usually, this high voltage can not gain by one sheet of electret. Therefore, 4 sheets were superimposed. Each sheet had 3.5kV. Charge density of the sheet was about 0.8mC/m². Thickness of the sheet was 75 micron meter. Material of the sheet was fluorine resin.

B. Experimental procedure

Figure 3 shows an explanation drawing of the procedure of the experiment.

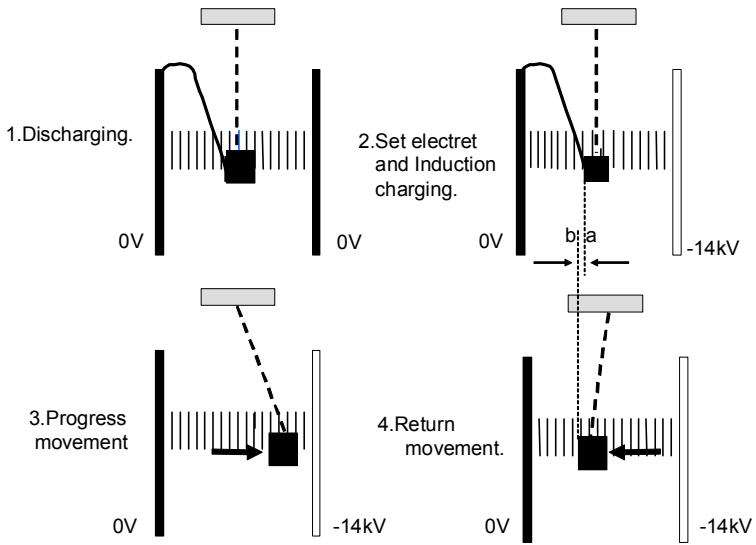

Fig. 3. A schematic of the experimental procedure

The experiment was performed using the following procedure:

- ①. The left and right electrodes were grounded, and the box conductor was touched to the grounded aluminum foil for discharging.
- ②. The electret was superimposed on the right electrode, and the box conductor was touched to the grounded aluminum foil again for induction charging. This position was defined as the start point "a" as shown in figure 3.
- ③. Then, the conductor was progressed toward the right side by the electrostatic force that acts on this charged box conductor.
- ④. Then, the conductor was returned toward the left side by the tension of the thread that acts on this box conductor. The terminal of the return movement was defined as the return point "b" as shown in figure 3.
- ⑤. Finally, the distance between the start point "a" and the return point "b" was measured from the movie that recorded those movement. The distance a-b was named as the overrun distance.

This experiment was repeated 48 times. These experimental results and the following simulation results will be shown later in the same graph.

III. SIMULATION

Figure 4 shows four different forces that act on the charged box conductor.

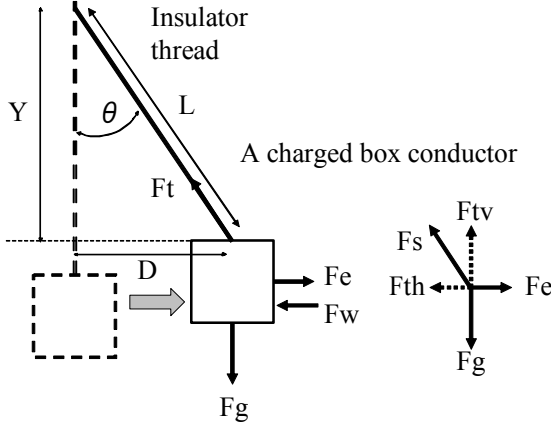

Fig. 4. Schematic diagram of the electrostatic force, the gravity force, the tension and the air resistance force that act on the charged box conductor on progress path.

There are four different forces that act on the charged box conductor of moving.

Namely, they are the electrostatic force \mathbf{fe} , the gravity force \mathbf{fg} , the tension \mathbf{ft} and the air resistance force \mathbf{fw} . The direction of the electrostatic force is x-plus. The direction of the horizontal component of the tension, and the air resistance force is x-minus. The direction of the vertical component of the tension is y-plus and the direction of the gravity force is y-minus. The strength of the vertical component of the tension is the same as the strength of the gravity force always. As a result, there is no force that acts on the charged box conductor in y-direction. Therefore, the charged box conductor is moved by the total force of the electrostatic force, the horizontal component of the tension and the air resistance force horizontally.

The electrostatic force was simulated with two dimensions finite difference method. The details of this method were reported on this conference a few times [2] [3]. Therefore, only the final results of this simulations are represented in this report.

Quantity of charge that was inducted in this box conductor was simulated as -6.72nC . Then, the strength of the electrostatic force that acts on this charged box conductor was simulated as 0.722mN .

The strength of the horizontal component of the tension \mathbf{Fth} can be calculated by the following formula (1) from the moving distance D , the thread length L and the gravity force F_g .

$$F_{th} = F_g \times \tan \vartheta = F_g \times \frac{D}{Y} = F_g \times \frac{D}{\sqrt{L^2 - D^2}} \quad (1)$$

where $L=150\text{mm}$, and $F_g=10.22\text{mN}$ that was calculated from area of the box is 38.64cm^2 , the thickness of the Al plate is 0.1mm and the specific gravity of Al is 2.70 .

The strength of the air resistance force can be calculated by the following formula(2):

$$F_w = \frac{C_d \times \rho \times S \times v^2}{2} \quad (2)$$

where C_d is air resistance constant, ρ is air density, S is the front space of the box conductor and v is velocity of the box conductor. Actually, $C_d = 1.0$, $\rho = 1.2 \text{ kg/m}^3$ and $S = 0.0006 \text{ m}^2$ was used in this calculation.

Figure 5 shows the simulated electrostatic force, the calculated horizontal component of the tension that was calculated from the formula (1) and the total force that acts on the charged box conductor. The air resistance force was not represented in this figure because the strength of it is very small.

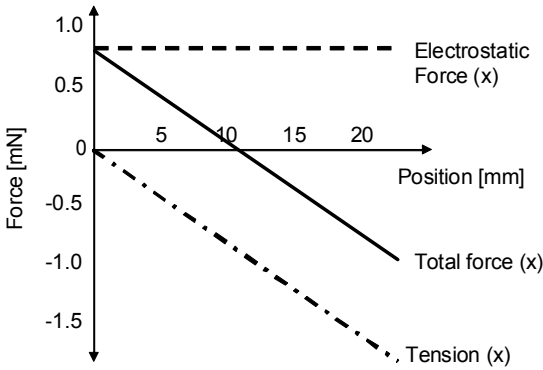

Fig. 5. The electrostatic force, the tension and the total force that acts on the charged box conductor.

It is apparent from figure 5 that the charged box conductor was accelerated from 0mm to 11mm and decelerated from 11mm to 22mm. The velocity of this charged box conductor was calculated from the total force that acts on this charged box conductor by solving a kinetic formula.

Figure 6 shows the calculated velocity of the charged box conductor.

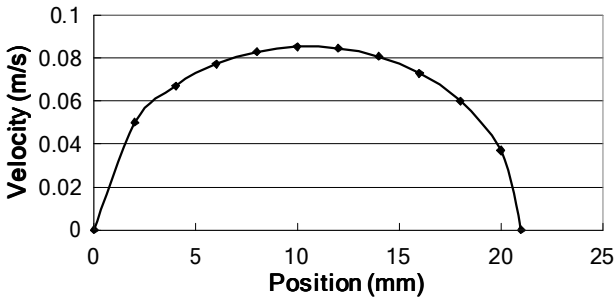

Fig. 6. The calculated velocity of the charged box conductor from the total force that acts on it by solving a kinetic formula.

It is apparent from figure 6 that the velocity of the box conductor becomes maximum at 11mm and it decreases to zero at 22mm. At this position, the charged box conductor stops, and it starts return movement to left. On this return path, the energy of the electric field in which the charged box conductor was progressed may be lost. Therefore, three cases of the energy pattern on the return path are possible. Fig.7 Shows the three cases of the energy pattern on the return path, and the original energy pattern on the progress path.

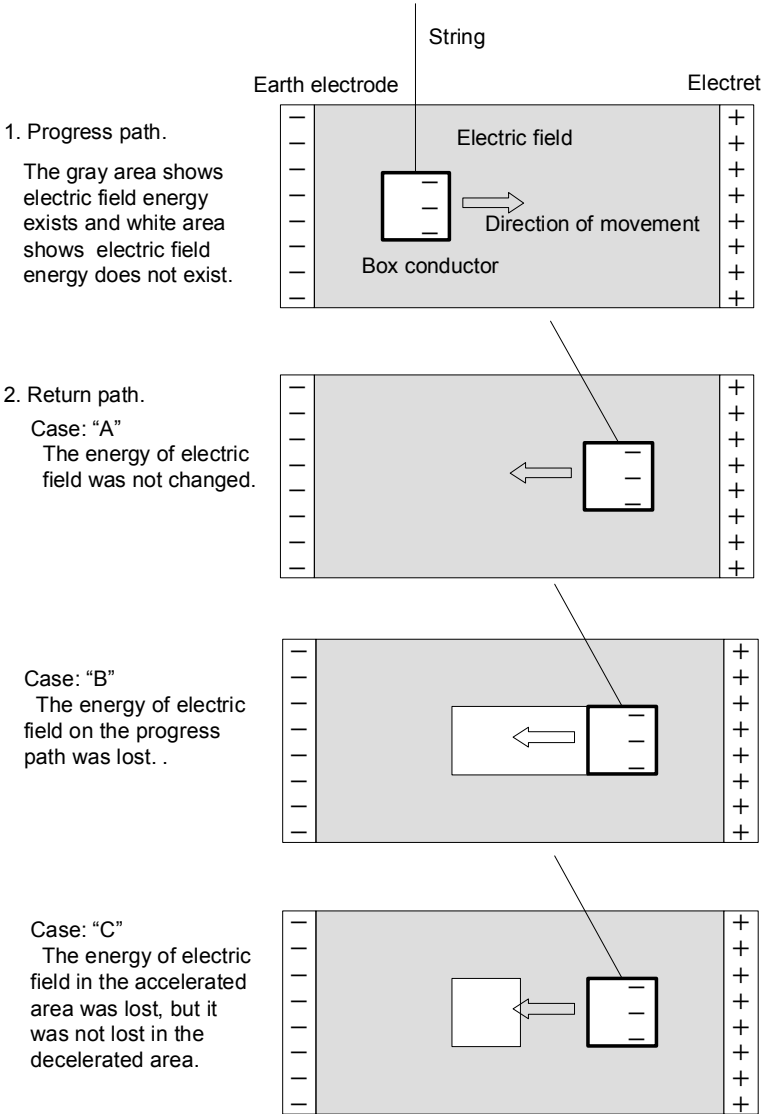
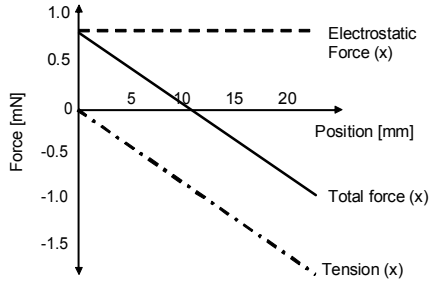

Fig. 7. The original energy pattern on the progress path and the three possible cases of the energy pattern on the return path,

Figure 8 shows the electrostatic forces that are corresponding for the three case of electric field pattern, the calculated horizontal component of the tension that was calculated from the formula (1) and the total force that acts on the charged box conductor in the return path. The air resistance force was not represented in this figure because the strength of it is very small.

Case: "A"

The box conductor is accelerated from 22mm to 11mm normally and it is decelerated from 11mm to 0mm normally.



Case: "B"

The box conductor is accelerated from 22mm to 11mm strongly and it is accelerated from 11mm to 0mm normally.

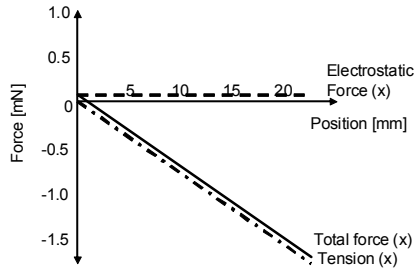

Case: "C"

The box conductor is accelerated from 22mm to 11mm normally and it is accelerated again from 11mm to 0mm normally.

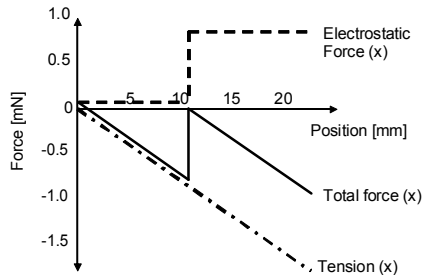

Fig. 8. The electrostatic forces that are corresponding for the three case of electric field pattern, the calculated horizontal component of the tension and the total force that acts on the charged box conductor in the return path. The air resistance force was not represented in this figure because the strength of it is very small.

It is apparent from figure 8 that the charged box conductor is accelerated from 22mm to 11mm by the total force gradually and decelerated from 11mm to 0mm by the total force gradually on the case "A". On the contrary, it is accelerated from 22mm to 11mm strongly and accelerated gradually on the case "B", and it is accelerated from 22mm to 11mm gradually and 11mm to 0mm accelerated gradually again on the case "C".

The velocity of this charged box conductor on the three cases was calculated by solving a kinetic formula.

Figure 9 shows the calculated velocity of the charged box conductor in the three cases.

Case: "A"

The velocity of the box conductor becomes maximum at 11mm and it decrease to zero at 0mm.

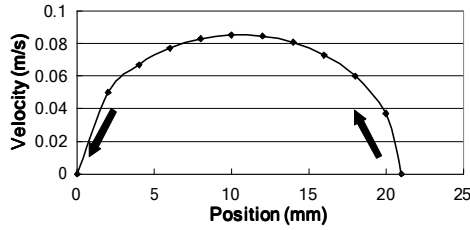

Case: "B"

The velocity of the box conductor becomes maximum at 0mm and it decrease to zero at -14mm.

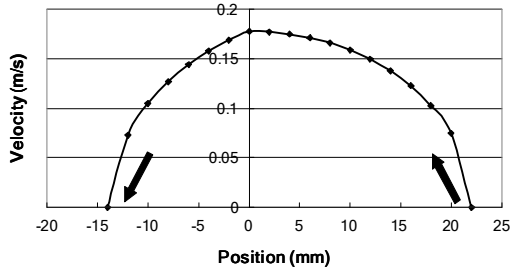

Case: "C"

The velocity of the box conductor becomes maximum at 0mm and it decrease to zero at -10mm.

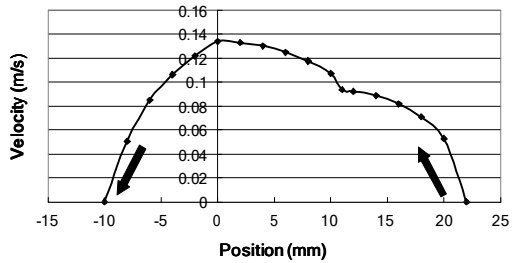

Fig. 9. The calculated velocity of the charged box conductor on the return path of the three cases of the electric field pattern.

It is apparent from figure 9 that the charged box conductor returns to the starting point (0mm) on the case "A". On the contrary, it passes over (overrun) the starting point long on the case "B" and case "C". The overrun distance is 14mm on the case "B" and it is 10mm on the case "C".

The actual overrun distances were measured by the simple experiment as described before. Figure 10 shows the simulated three overrun distances and the measured 48 overrun distances.

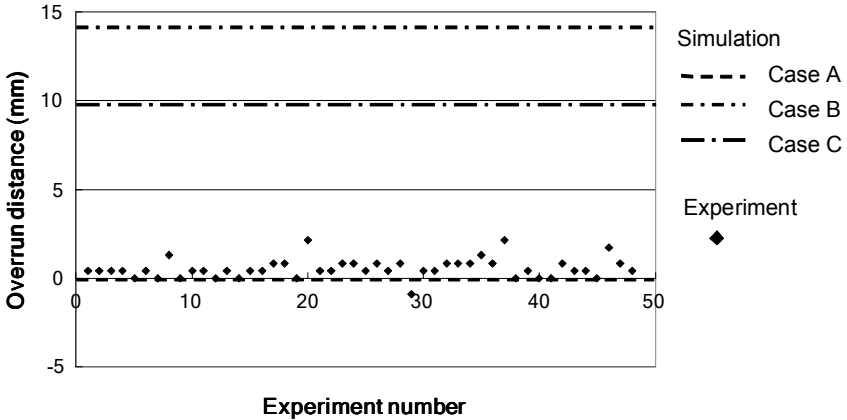

Fig. 10. The simulated overrun distances of the three cases and the measured overrun distances by the simple experiment.

IV. COSIDERATION

It is apparent from figure 10 that the 48 measured overrun distances almost agree with the simulated overrun distance on the case "A". On the contrary, the simulated overrun distances of the case "B" and "C" do not agree with the measured overrun distances. Therefore, it should be concluded that case "A" is real situation. Namely, the electric field pattern was not changed even if the charged box conductor was moved by electric force originated from the electric field.

Of course the measured overrun distance is not zero. The average of the 48 measured distances is 0.7mm. This little difference can be explained by a charge leak phenomenon.

It is well known that charges on the surface of a conductor leak gradually into the air with time. The leak speed depend on the humidity. The experiment was performed in low humidity. It was 30%RH. This was not perfect condition for preventing the charge leak phenomenon. If 5% charge leaks on the progress path, the simulated overrun distance becomes 1mm or less. This result agrees well with the average of the 48 measured overrun distances.

Finally, a big question remains. The charged box conductor gained kinetic energy from the electric field. Namely, the electric field gave kinetic energy to the charged box conductor. Nevertheless the electric field did not change. Therefore, the same energy must be supplied to the energy lost electric field.

Any one ? How to?

I can not answer this question.

I sought the answer in inter net site and books. I found a book [4]. Its title is " what is the field?" This soft cover book was written by Dr. Kaoru Takeuchi, and published by Kodansha Ltd in 2000 in Japanese language. Its contents is very difficult for me. The following is my understanding. This is may be correct, or may be misunderstanding.

"Every electron radiates photons continuously all around direction. Vibration of the photons makes an electric field."

I think this means that the electric energy is always transferring with light velocity in the electric field . Therefore, if the electric field give kinetic energy to the charged box conductor, the space is repaired by the following photons. As a result, the electric field looks like no change.

I believe this explanation is correct. But, there is a big question. Can the electron radiated photons forever ?

My stupid answer is "Electron sends negative energy to proton and receives positive energy from proton. Then, the electron changes the positive energy into negative energy and sends it to proton again. As a result, electron and proton change the same energy each other. Therefore, electric field never change forever."

V. CONCLUSION

It was confirmed by a simple experiment that the same space can give the same electric energy to a charged conductor again even if the space gave an electric energy to the charged conductor.

This experimental result means the energy of an electric field is not static, and furthermore it must be dynamic. This dynamic electric field can be explained by photon radiated from electron.

An electrostatic generator [5] that is driven by the electric field energy originated from electret will be realized in the near future.

ACKNOWLEDGEMENTS

Author would like to thank Mr. Susumu Kawato and Mr. Satoshi Shimizu (TOHO KASEI CO., LTD.) for the effort of trial manufacture of the very high voltage electret.

REFERENCES

- [1] Jearl Walker, *Fundamentals of Physics*. 8th Edition John Wiley & sons ,Inc. 2008, pp. 671.
- [2] Katsuo Sakai, "The electrostatic force that acts on the charged asymmetric conductor in a high electric field," Proceedings of 2009 Electrostatics Joint Conference (2009) P2.07
- [3] Katsuo Sakai, "Electrostatic force that acts on non-sphere shape charged conductors", Proceedings of 2010 ESA annual Conference (2010) G4
- [4] Kaoru Takeuchi, *What is the field?*. Kodansha Ltd. 2000 in Japanese, pp. 54.
- [5] Katsuo Sakai, *Asymmetric Electrostatic Forces and a New Electrostatic Generator*, first ed. Nova Science Publish, New York, 2010