

# ESA Newsletter

Electrostatics Society of America - The Friendly Society

## President's Message

Dear Colleagues,

Being a professor, people sometimes ask me if the current university model, with its high costs, will be sustainable. Will the internet make physical universities obsolete?

Over the past few years, many "MOOCs" – Massive Open Online Courses – have become available. The MOOCs are often taught by leading experts and produced in very high quality by specialized companies. They are carefully edited so that they do not have the hiccups of live courses. Students can watch the lectures at times convenient to them and at their own pace. Most significantly, the MOOCs are totally free.

But I question whether MOOCs really provide new value. Books have been easily available since the advent of the printing press centuries ago. A student can learn just as well by reading a book as by watching a lecture – in fact, a person can read more quickly than a person can talk, so reading a book is a more efficient way to learn than listening to a lecture. While MOOCs offer online problem sets that are graded automatically, a student can do the same off-line by working out problems from a textbook and checking with answers given in a solutions manual.

So I don't think that MOOCs really offer value that was not already provided in books. Universities have thrived over the centuries even though books have been available. Therefore, I don't think that MOOCs will be a threat to physical universities.

So what is it that physical universities offer that MOOCs cannot match? I think two obvious advantages are of a non-academic nature. First, universities offer the prestige of degree from a reputable institution. Second, the university environment is an enjoyable place for a 20-year old – would one really prefer to sit at home on a computer?

But more importantly, there is an academic factor that MOOCs cannot match – the interaction with peers. At a university, most learning does not occur in lectures. Lectures merely provide a guide to the students, and the actual learning process occurs when students actively tackle the material on their own. While this learning can occur by students working individually, it is often enhanced by interactions with other students, including team based activities as well as informal discussions outside of class. This peer-based learning goes beyond course material – intellectual discussions on diverse topics are an important part of the university experience. These peer interactions cannot be captured online.

I believe the ESA Annual Meetings similarly play a role that cannot be duplicated online. We can read journal articles or watch online videos about electrostatics research, but there is no substitute to in-person discussions with colleagues. The interactions with ESA colleagues have had a big impact on my career, as I have been describing in my newsletter messages.

So I hope you will take advantage of the in-person interactions at the 2014 ESA Annual Meeting, which will be held June 17-19 at the University of Notre Dame!

Regards,  
 Dan Lacks,  
 President, ESA

## ESA Officers

### President:

Dan Lacks, Case Western Reserve Univ.

### Vice President

Shesha Jayaram, Univ. of Waterloo

### Executive Council

Sheryl Barringer, Ohio State Univ.

Kelly Robinson, Electrostatic Answers, LLC

Rajeswari Sundararajan, Purdue Univ.

## Calendar

- ✓ EIC 2014, June 8-11, 2014, Philadelphia, PA, USA, <http://sites.ieee.org/eic/>
- ✓ ESA 2014, June 17-19, 2014, Univ. of Notre Dame, South Bend, Indiana, USA, David Go, [dgo@nd.edu](mailto:dgo@nd.edu)
- ✓ SFE 2014 (9<sup>th</sup> Conf.) Aug. 27-29, 2014, Toulouse, France, [secretariat-sfe2014@laplace.univ-tlse.fr](mailto:secretariat-sfe2014@laplace.univ-tlse.fr) (abstract due Jan. 31, 2014)
- ✓ ESA 2015, June, 2015, Cal Poly Pomona, Pomona, CA, USA, Keith Forward, [kmforward@csupomona.edu](mailto:kmforward@csupomona.edu)

## ESA2014 - Electrostatics Demonstration

At the upcoming ESA Meeting set for June 17-19, 2014 at the University of Notre Dame in Notre Dame, Indiana plans are afoot for a special evening workshop and reception devoted to electrostatics demonstrations. The goal is to provide a variety of demonstrations from educational experiments to safety and consultation topics, building upon the very successful demonstration workshop at the 2012 ESA/IEJ/IAS/SFE joint meeting at the University of Waterloo. The event is slated to take place on the campus of the University of Notre Dame, adjacent to where the conference talks will be held and close to all the lodging options. We are currently looking for volunteers to run their own demonstration. If you have a favorite demonstration to share or have an idea for a new one, this is the event for you.

If you have questions or suggestions for this session, please feel free to contact Kelly Robinson, who will be coordinating the workshop.

*Kelly Robinson, PE, PhD*

*Owner, Electrostatic Answers*

*[kelly.robinson@electrostaticanswers.com](mailto:kelly.robinson@electrostaticanswers.com)*

## Current Events

### Wind power without wind turbines

*Leland Teschler*

Researchers at Delft University of Technology in the Netherlands have crafted a way of harvesting energy from the wind that eliminates the need for turbine blades, gearboxes, generators, and other assemblies normally found in wind turbines. Called the EWICON (short for Electrostatic WIndenergy CONvertor), the device uses principles of electrostatics to produce electrical current.

A demonstration unit constructed by an architectural firm called Mecanoo is now on the Delft University campus. The EWICON has no moving parts. The only pieces that can wear out are nozzles that spray water droplets which serve as charge carriers. As Mecanoo describes it, the hardware consists of a flowing steel frame in the shape of a squared -0- supporting a framework of horizontal steel tubes. Electrically charged droplets are created within the framework and are blown away by the wind. The movement of the droplets creates an electric current, which can be passed on to the grid.

Many details pertaining to principles of the device's operation can be gleaned from a dissertation developed by Delft researcher D. Djairam. As Djairam writes, allowing

the wind to force charged particles against the direction of an electric field boosts the potential energy of these charged particles. The charged particles can then be collected in a charging system that is insulated from earth. Because the charging system starts out electrically neutral, dispersing charged particles causes its potential to rise. Basically, the earth acts as the collector for the charged particles in the EWICON system. The system itself is insulated from earth and the dispersal of charged particles will increase the potential of the system. In theory, the charged particles could be anything that could hold

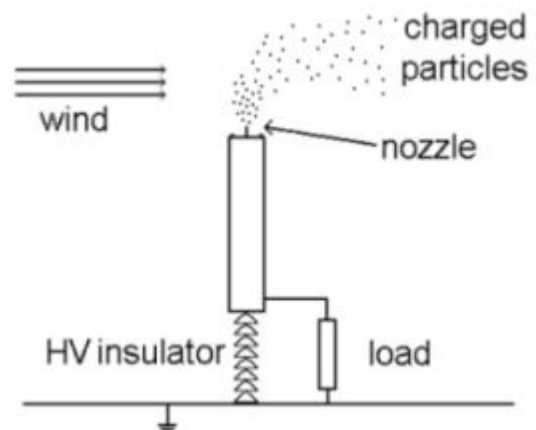



# 2014 Annual Meeting of the Electrostatics Society of America

University of Notre Dame, Notre Dame, IN  
June 17-19, 2014

The Electrostatic Society of America (ESA) invites papers in all scientific and technical areas involving electrostatics for the 2014 Annual Meeting of the ESA. Contributions range from fundamental physics and new developments in electrostatics to applications in industry, atmospheric and space sciences, medicine, energy, and other fields.

## Anticipated Technical Session Topics

- Breakdown phenomena and discharges
- Electrically-induced flows and electrokinetics
- Contact charging and triboelectric effects
- Gas discharges and microplasmas
- Atmospheric and space applications
- Biological and medical applications
- Materials synthesis, processing, and behavior
- Measurements and instrumentation
- Safety and hazards



## Keynote Speakers

We are excited to have confirmed an excellent slate of keynote speakers:

- **Dr. Giles Harrison**, University of Reading, UK
- **Dr. Sung-Jin Park**, University of Illinois Urbana-Champaign and Eden Park Illumination, USA
- **Dr. Hak-Kim Chan**, University of Sydney, Australia
- **Dr. Junhong Chen**, University of Wisconsin-Milwaukee, USA
- **Dr. Peter Ireland**, University of Newcastle, Australia

## Special Events

Electrostatics Demonstration Workshop and Reception, and the Annual ESA Banquet.

## Student Presentation Competition

Presentations by undergraduate and graduate students are eligible for the Student Presentation Competition. Please indicate student presenter when submitting abstract.

## Important Dates

January 1, 2014 *Abstract submission open*  
March 1, 2014 *Abstract submission deadline*  
March 15, 2014 *Notification of abstract acceptance*  
May 10, 2014 *Early registration deadline*  
May 15, 2014 *Final manuscript deadline*

## Abstract Submission

Online submission at <http://www.electrostatics.org>

## Contact Information

### General Chair

Prof. David B. Go ([dgo@nd.edu](mailto:dgo@nd.edu))  
University of Notre Dame, USA

### Technical Chair

Prof. Poupak Mehrani ([poupak.mehrani@uottawa.ca](mailto:poupak.mehrani@uottawa.ca))  
University of Ottawa, Canada

## Current Events (cont'd.)

an electrical charge. But water droplets turn out to be the most practical way of dispersing streams of charged particles, says Djairam. But there's a limit to the amount of charge that a liquid droplet can hold before it will break up into smaller droplets, and that charge depends on the natural surface tension of the liquid. Evaporation is also an issue because the charged droplets need to survive until they reach the earth.

One wonders how much water would be necessary in this scheme to generate meaningful amounts of power. Here's how researchers approached this issue: They calculated the work done on a droplet by the wind using some reasonable assumptions and came up with about  $1.13 \times 10^{-8}$  J. Assuming a spray nozzle dispersing about 107 droplets/sec or 20 ml/hr (not unreasonable, they say) gives a power associated with this stream of droplets of 113 mW/nozzle. A  $30 \times 30$  array of these nozzles would produce about 102 W. Assuming water droplets with a diameter of  $5 \mu\text{m}$  charged to 70% of the maximum theoretical charge (given by the Rayleigh limit), the rate of charged droplets is  $8.5 \times 10^7/\text{sec}$ , corresponding to a current through each nozzle of  $4.7 \mu\text{A}$ . This would imply an output power of roughly 0.5 W into an electrical load of  $20 \text{ G}\Omega$ .

In real systems, not all droplets will get completely charged. Researchers assumed a conversion efficiency of 25%, implying a need for 212 nozzles/ $\text{m}^2$  to produce the current required to feed such a load. If the droplets have a diameter of  $15 \mu\text{m}$ , the current drops to  $0.9 \mu\text{A}$  per nozzle, they say, which implies an output power of 17 mW, implying the system would consist of roughly 5,500 spraying nozzles/ $\text{m}^2$ . In terms of liquid consumption, this equals going from 4.2 l/hr for the former situation to 110 l/hr for the latter.

Another issue: Creating an electric field in a way that the system doesn't consume more energy than it generates. Researchers considered several techniques but found two particularly promising. The first is electrohydrodynamic atomisation (EHDA) often used for applying coatings where a strong electric field focuses the meniscus of the liquid leaving a spraying nozzle into a conical shape. Ions in the liquid accelerate toward the cone apex and, consequently, accelerates the liquid itself. At the cone apex, liquid breaks up into droplets with a high charge density.

The second promising method of creating charged droplets is called high pressure monodisperse spraying (HPMS). It is basically ink jetting: Liquid is forced through small micron-sized pores with equal size creating liquid jets with equal diameter. The high pressure that is applied is usually in the order of 10 to 15 MPa. The liquid jets

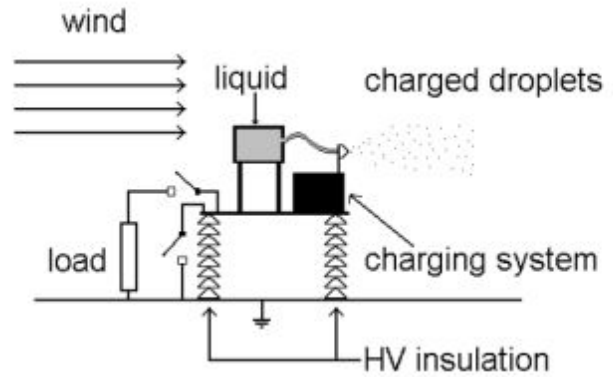

Schematic of the EWICON prototype. A reservoir supplies the liquid to the isolated charging system, where charged droplets are produced.

break up into droplets with the diameter of the droplet proportional to the diameter of the liquid jet.

Another issue is that of remaining energy positive even considering the energy needed to pump meaningful amounts of water to the system. As an example, say researchers, assume water needs to be pumped to a height of 10 m at a flow rate of 400 l/hr. In that case, the minimum required pumping power works out to be 11 W, roughly 1% of the rated power. Currently, the maximum efficiency of water pumps is roughly 90% which means that the required power will actually be 12 W. However, if the charging and spraying efficiency is lower and the output power per nozzle is, for example, 5 mW or 0.5 mW at the same flow rate, then the minimum required pumping power would be 121 W or 1.2 kW respectively. In the latter case, you end up with a net energy debit.

Thus pumping energy is a big issue, and researchers think these systems might make the most sense where they can take advantage of such fortunate happenstances as rain water collection above the height of the wind generation system.

And other issues arise when the EWICON concept is scaled up. Several nozzles ganged together should produce electrical current equal to the sum of that produced by individual nozzles. But to their dismay, researchers found that the current produced by each single nozzle was significantly lower compared to a single nozzle/ring electrode configuration. The maximum current per nozzle was  $0.2 \mu\text{A}$  compared to  $0.5 \mu\text{A}$  measured with a single needle nozzle. A nine-nozzle configuration did not yield  $2.7 \mu\text{A}$  as researchers expected based on the individual nozzle result, but slowly reached  $1.5 \mu\text{A}$  as the number of nozzles rose. Researchers say the reason(s) why this non-linearity is present are still a topic of ongoing research and constitute one of the most important issues that must be resolved to make the EWICON system scalable.

## Current Events (cont'd.)

All things considered, researchers are leaning toward using HPMS to generate charged water drops. Their best multi-nozzle system result used six such nozzles spraying a water/ethanol mixture, which produced an output power per nozzle of 2.1 mW. A 1 kW version using this configuration would require  $4.8 \times 10^5$  spraying nozzles, roughly  $700 \times 700$  nozzles occupying  $14 \times 14$  m<sup>2</sup> assuming 2-cm spacing. Researchers say this means spraying nozzles must be more closely packed before a kilowatt version will be economical. For HPMS, even with lower-than-expected charging efficiencies, the increase in produced current should be feasible, they think.

(from <http://machinedesign.com/archive/wind-power-without-wind-turbines>)

### New satellite sail is propelled by solar protons

Jacob Aron

A tiny new satellite is propelled by repulsion. ESTCube-1, which went into orbit on Tuesday, May 7, will put proton-powered electric solar sails to the test for the first time. It could pave the way for speedy trips through the solar system.

Regular solar sails have large, thin mirrors that reflect photons from the sun to push the spacecraft forward. The new electric sail, proposed in 2008, harnesses solar protons instead. Wires with a positive charge will extend from the craft and repel protons – also positively charged – to propel the tiny satellite.

ESTCube-1 is 10 centimetres wide and has a 10-metre-long wire just half the width of a human hair. It is within the Earth's magnetosphere, so is shielded from the solar wind, but it will still interact with charged particles, says Mart Noorma of Tartu University in Estonia, who helped develop the satellite. Once the wire is fully extended and powered up, the satellite's rotation rate should alter, letting the team measure the thrust generated by the electric sail. If the tests are successful, the hope is that a full-sized craft with 100 wires, each 20 kilometres long, could reach speeds of 30 kilometres per second, fast enough to get to Pluto in under five years. Smaller sails could act as a brake for retired satellites, slowing them down enough to fall safely back to Earth. (from <http://www.newscientist.com/article/dn23498-new-satellite-sail-is-propelled-by-solar-protons.html#.UnbrvShxLRo>)

### UC Santa Barbara Study Provides a New Framework for Understanding the Energetics of Ionic Liquids

A new study by researchers at UC Santa Barbara provides clues into the understanding of the behavior of the charged molecules or particles in ionic liquids. The new framework may lead to the creation of cleaner, more sustainable, and nontoxic batteries, and other sources of

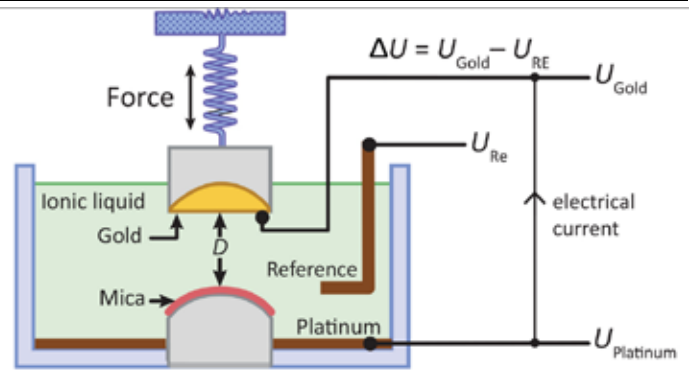

chemical power. The research was published in an early online edition of the Proceedings of the National Academy of Sciences. "I think this framework would provide a nice strategy to begin discussions toward batteries utilizing ionic liquids," said graduate student researcher Matthew Gebbie, first author of the paper, "Ionic liquids behave as dilute electrolyte solutions."

An electrolyte is a compound that is dissolved in a solution — usually water — in order to separate the individual, charged atoms of the compound. Take, for example, sulfuric acid dissolved in water to provide the free ions that create the charge given off by automotive batteries. Electrodes pick up the positively and negatively charged ions and deliver the current where it's needed to start the car or power electrical components.

An ionic liquid is a salt — like rock salt but in the liquid state — usually one that can melt at temperatures from ambient room temperatures to 100 degrees Celsius (212 degrees Fahrenheit), so the liquid is composed entirely of homogenous molecules with positive and negative charges (ions). "You'd expect that at room temperature, with ionic liquids that are made entirely of positive and negative charges, that the ions should be mobile," said Jacob Israelachvili, professor in the Departments of Chemical Engineering and Materials.

But, despite the abundance of ions and a free-flowing environment, ionic liquids have never lived up to their promise of delivering the same kind of energy as currently available electrolytes, like sulfuric acid. Their conductivity is just not as high, said the scientists.

Using a surface forces apparatus, a device developed in the Israelachvili lab that can measure forces between surfaces to the sub-nano scale, the researchers analyzed the interactions of the charges in an ionic liquid — how the surfaces attract or repel each other, the effective voltage of the liquid, and the ions' interactions with each other, as well as with the electrodes that are meant to pick up or discharge, and thereby conduct their charges.



## Current Events (cont'd.)

They found that the ions in the ionic liquids are "stickier" than previously thought. "They're bound to each other, and it's related to a complex property of any liquid or material, called the dielectric constant, which is the measure of how much you would expect charges to be free," explained Israelachvili. In fact, the somewhat-overlooked dielectric constant, which is a measure of how well charged particles stick to each other in a liquid, plays a larger role in the conductivity of ionic liquids than was previously assumed. Instead of the estimates of 50 percent separation that have been made, the experiments with the surface forces apparatus yielded a less than 0.02 percent separation between ions for typical ionic liquids.

"The connection that nobody had made before that emerged from our work was that it's not enough just to know how sticky the ions are to each other in a vacuum; you need to account for all the other billions of ions that surround any two ions in the liquid state," said Gebbie.

With that parameter taken into account along with the materials' dielectric constant, said the scientists, it became possible to come up with a simple equation that can

quantitatively predict the number of free — effectively separated — ions that are present in ionic liquids. "It's so simple. It really captures the physics of what's going on, but it's also simple enough to be used for predictive purposes," said Gebbie, adding that the group is now in active discussions with potential collaborators to refine and improve the equation.

The research has wide implications. With the formula, it would be possible to design an ionic liquid with particular desired properties, instead of performing countless trial-and-error tests or experiments. To date, over a million combinations of positive and negative ions have been identified that can be mixed together to form an ionic liquid, according to the researchers. To further blend these liquids to find, change, or add properties, the number of possible combinations shoots up to about  $10^{18}$ , or a trillion trillion potential combinations. Not only could efficient charge-conducting ionic liquids be found in a shorter amount of time, but other properties could also be incorporated via molecular fine-tuning, such as less toxicity, reduced corrosiveness, or increased biodegradability.

"An electric vehicle has to have a very large battery. So if that very large battery is based on something that's acid, then you have a large compartment of acid. In an accident, if you had a nonflammable, nontoxic ionic liquid, then at least you could take some of that risk out of the equation," said Gebbie.

(from <http://www.ia.ucsb.edu/pa/display.aspx?pkey=3034>)

### Spider Webs Capture Electrically Charged Prey

Jennifer Viegas

Similar to electrostatic dust cloths, spider webs attract electrically charged prey. The electricity, in this case, is derived from flapping. The discovery, outlined in the latest issue of *Scientific Reports*, could help to explain how spider webs evolved. Light, flexible spider silk easily deforms in the wind and electrostatically charges to aid prey capture. Were it not for such flexibility, the flying insect could just bounce off and zip on its way.

"Electrostatic charges are everywhere, and we propose that this may have driven the evolution of specialized webs," Victor Manuel Ortega-Jimenez, a UC Berkeley researcher who worked on the study, said in a press release. Ortega-Jimenez most often studies hummingbird flight, but he had a light bulb moment while playing with his 4-year-old daughter. "I was playing with my daughter's magic wand, a toy that produces an electrostatic charge, and I noticed that the positive charge attracted spider webs," he said. "I then realized that if an insect is positively charged too it could perhaps attract an oppositely

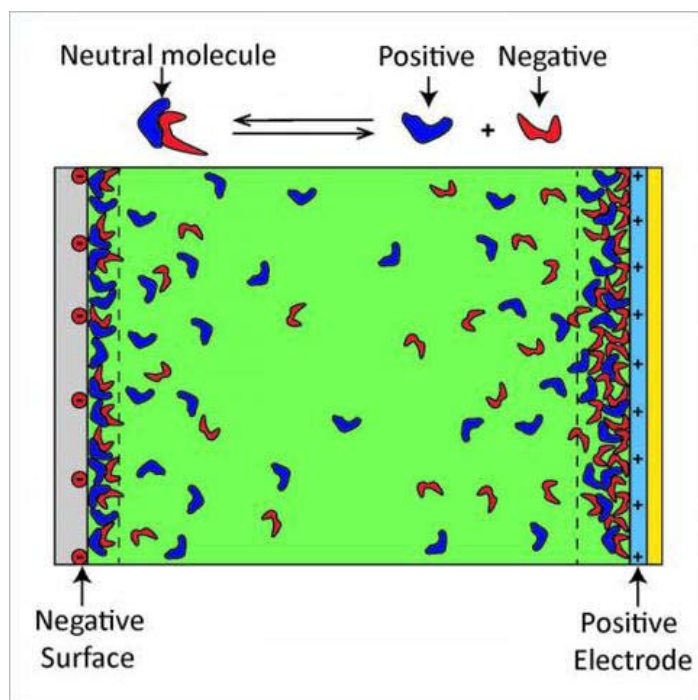

This is a cartoon depicting how the ionic liquid molecules arrange in electrically charged interfaces (not to scale). The green shading represents the 99.98% of the molecules that exist in a neutral state, the blue shapes represent positive ions and the red shapes represent negative ions. The reaction shown above the cartoon illustrates the fact that the molecules can exist in two states: a neutral ionic liquid molecule (99.98% of the molecules) and separated positive (blue) and negative (red) ions (0.02% of the molecules).

## Current Events (cont'd.)

charged spider web to affect the capture success of the spider web.”

To test this, he gathered a bunch of cross-spider webs and brought them into his lab. Then, like Dr. Frankenstein, he used an electrostatic generator to charge up dead insects. These included aphids, fruit flies, green-bottle flies and honeybees. Once charged, all were then dropped one by one onto a neutral, grounded web. “Using a high speed camera, you can clearly see the spider web is deforming and touching the insect before it reaches the web,” he said. Insects without a charge did not do this. “You would expect that if the web is charged negatively, the attraction would increase.”

Microfiber and electrostatic dust cloths utilize a similar process. Because of its structure, microfiber is positively charged. Like a magnet, it can then attract negatively charged dirt and dust. Tiny hooks in the fabric trap the dust in, which is why you often have to rinse, throw out, or vigorously shake such dust cloths after use.

Insect-generated electricity has also been shown to help bees to communicate with plants and vice versa. There’s been a fair amount of focus on electrically charged bees and insects these days, with all kinds of interesting findings like this. The electricity from our perspective is minimal, although insects easily develop several hundred volts of positive charge from the friction of wings against air molecules or by contacting a charged surface. By comparison, we develop several thousand volts of electricity when walking across a rug, or even when petting a cat. That’s why you can get a shock right afterward when you touch something metal, such as a metal doorknob. The electrostatic charge of a bee is sufficient to draw pollen off a flower before even landing, saving the bee a lot of work.

In the future, Ortega-Jimenez hopes to find out whether static charges on webs attract more dirt and pollen. If so, that could be why many spiders rebuild their webs on a daily basis.

(excerpted from <http://news.discovery.com/animals/insects/spider-webs-capture-prey-charged-with-static-electricity-130708.htm>)

### Physicists pinpoint key property of material that both conducts and insulates

Vince Stricherz

It is well known to scientists that the three common phases of water – ice, liquid and vapor – can exist stably together only at a particular temperature and pressure, called the triple point. Also well known is that the solid form of many materials can have numerous phases, but it is difficult to pinpoint the temperature and pressure for the points at which three solid phases can coexist stably.

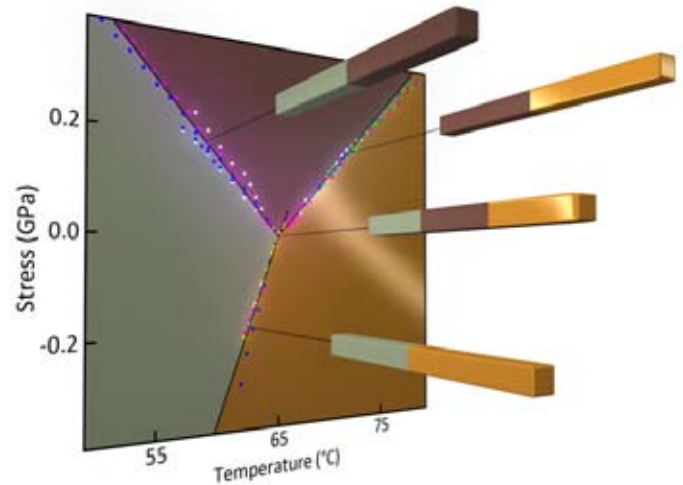

The lines of data points are where two of the three solid-state phases of vanadium dioxide can exist stably together, and the point where the three lines meet – the triple point – is where all three phases can exist together.

Scientists now have made the first-ever accurate determination of a solid-state triple point in a substance called vanadium dioxide, which is known for switching rapidly – in as little as one 10-trillionth of a second – from an electrical insulator to a conductor, and thus could be useful in various technologies. “These solid-state triple points are fiendishly difficult to study, essentially because the different shapes of the solid phases makes it hard for them to match up happily at their interfaces,” said David Cobden, a University of Washington physics professor. Cobden is the lead author of a paper describing the work, published Aug. 22 in *Nature*.

In 1959, researchers at Bell Laboratories discovered vanadium dioxide’s ability to rearrange electrons and shift from an insulator to a conductor, called a metal-insulator transition. Twenty years later it was discovered that there are two slightly different insulating phases. The new research shows that those two insulating phases and the conducting phase in solid vanadium dioxide can coexist stably at 65 degrees Celsius, give or take a tenth of a degree (65 degrees C is equal to 149 degrees Fahrenheit). To find that triple point, Cobden’s team stretched vanadium dioxide nanowires under a microscope. The team had to build an apparatus to stretch the tiny wires without breaking them, and it was the stretching that allowed the observation of the triple point, Cobden said.

It turned out that when the material manifested its triple point, no force was being applied – the wires were not being stretched or compressed.

(excerpted from <http://www.washington.edu/news/2013/08/22/physicists-pinpoint-key-property-of-material-that-both-conducts-and-insulates/>)

**Electrostatics  
Society of America**



**30 Shalimar Drive  
Rochester, NY 14618**

### **ESA Information**

ESA Home Page: <http://www.electrostatics.org>

Dan Lacks  
ESA President  
Department of Chem. Eng.  
Case Western Reserve Univ.  
Cleveland, OH 44106  
(216)368-4238  
[daniel.lacks@case.edu](mailto:daniel.lacks@case.edu)

Steve Cooper  
Secretary/Treasurer  
540 Morton Rd.  
Athens, GA 30605  
706-255-5518  
[steve@mt-ind.com](mailto:steve@mt-ind.com)

Mark Zaretsky  
Newsletter Editor  
30 Shalimar Drive  
Rochester, NY 14618  
585-588-6351  
[mark.zaretsky@kodak.com](mailto:mark.zaretsky@kodak.com)

**ESA-2014 Annual Meeting  
June 17-19, 2014  
University of Notre Dame  
South Bend, Indiana, USA**